



Starter/Extension Balustrade & Gate Kit Installation Guide

How to install your balustrade starter and/or extension packs

Within this guide, we will provide step-by-step instructions on how to install our balustrade and gate kit systems.

Our kits are available in White and Anthracite Grey:



Routing comes as Square:



Contents:

1828mm (6ft) PVC Balustrade Starter Pack

- 1 x 1828mm White/Anthracite Grey Top Rail
- 1 x 1828mm White/Anthracite Grey Bottom Rail
- 2 x Top Rail Brackets
- 2 x Bottom Rail Brackets
- 2 x 1828mm Steel U Channel Rail Reinforcing
- 1 x Bottom Rail Foot Block
- 14 x 945mm x 38mm White/Anthracite Grey Pickets
- 16 x 30mm Countersunk Wood Screws
- 13 x 4.8mm x 19mm Reinforcement Screws
- 2 x 1828mm White/Anthracite Grey 102mm x 102mm Post Sleeves
- 2 x Post Caps White/Anthracite Grey
- 2 x Post Skirts White/Anthracite Grey

1828mm (6ft) PVC Balustrade Extension Pack

- 1 x 1828mm White/Anthracite Grey Top Rail
- 1 x 1828mm White/Anthracite Grey Bottom Rail
- 2 x Top Rail Brackets
- 2 x Bottom Rail Brackets
- 2 x 1828mm Steel U Channel Rail Reinforcing
- 1 x Bottom Rail Foot Block
- 14 x 945mm x 38mm White/Anthracite Grey Pickets
- 16 x 30mm Countersunk Wood Screws
- 13 x 4.8mm x 19mm Reinforcement Screws
- 1 x 1828mm White/Anthracite Grey 102mm x 102mm Post Sleeve
- 1 x Post Cap White/Anthracite Grey
- 1 x Post Skirt White/Anthracite Grey

Post to Subframe Fixing Kit

- 4 x Sub Frame Brackets Stainless Steel
- 2 x Coach Bolts 100mm per Bracket
- 6 x 40mm Pan Head Wood Screws per Bracket

Gate Kit

- 1 x Gate 960mm x 950mm
- 2 x Hinges with Screws
- 1 x Latch & Lock with Screws

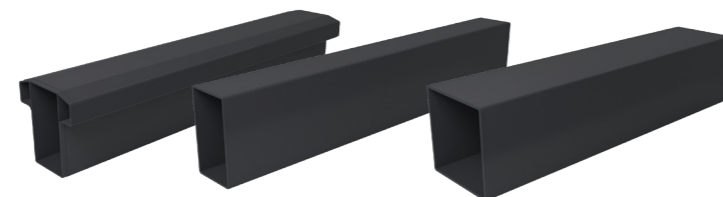

Top Rail - Routed

Bottom Rail - Routed

Post Sleeve

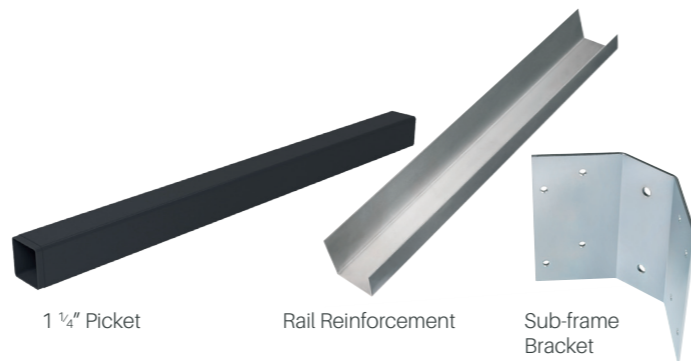

1 1/4" Picket

Rail Reinforcement

Sub-frame Bracket

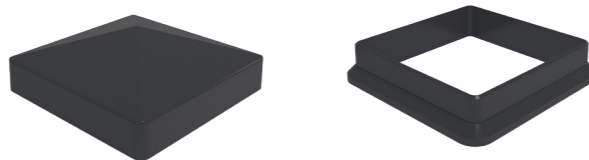

Post Cap

Post Skirt



Top Rail Bracket

Bottom Rail Bracket



Fixings

Foot Block



Gate



Latch



Hinges x 2



HOW TO INSTALL POSTS

Single Post Kits - 3 items:
Double Post Kits - 6 items:

1 x 1828mm (6') Post, 1 x Post Cap, 1 x Post Skirt.
 2 x 1828mm (6') Posts, 2 x Post Caps, 2 x Post Skirts.

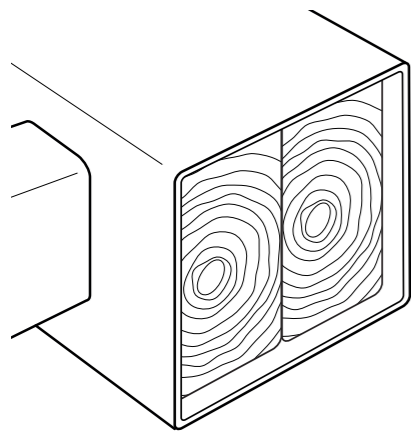
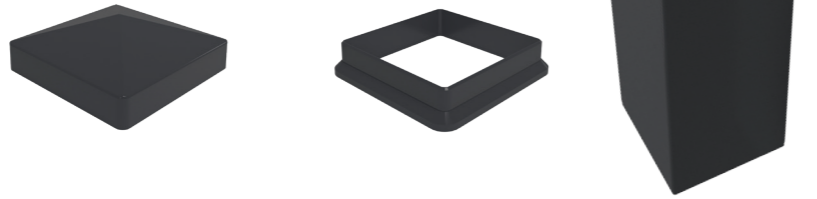

1. Post requires reinforcing with timber at nominal 95mm x 95mm - alternatively 2 off 95 x 47mm timbers screwed together at max 400mm centres can be used. Timber should be class C16 or C24. It is also recommended that timber is glued on mating faces.
2. Post and timber should be supported on a level solid base such as concrete pad.
3. Posts should be secured to deck sub-frames using one of the following methods:
 - Corners - using a Sub-Frame Bracket
 - Mid - Cross Lap Style: let into the sub-frame and supported with a backing timber on the inner side.
4. Post caps should be secured with low modulus neutral cure silicone.
5. Post skirts are used to mask the cut/expansion gap of the deck planks. Where required, skirts should be trimmed to fit and secured with low modulus neutral cure silicone.

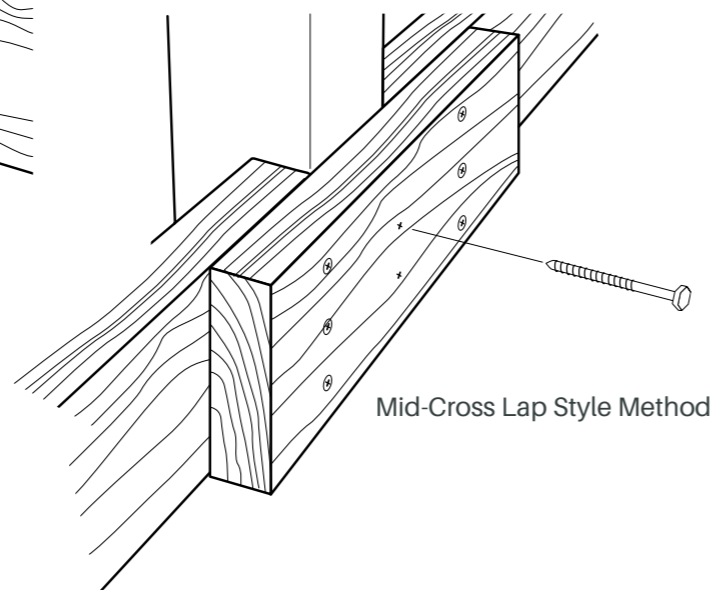
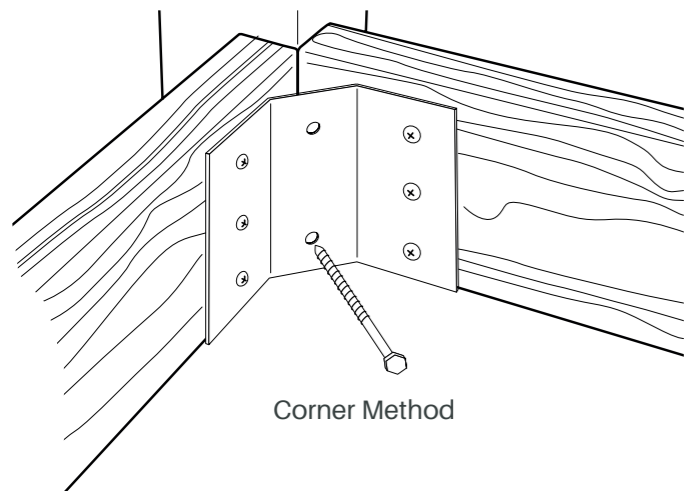

HOW TO INSTALL BALUSTRADE STARTER OR EXTENSION KITS

Top Rail, Bottom Rail, 2 x Top Brackets, 2 x Bottom Brackets, 2 x U Channel Reinforcements, Foot Block, Pickets 945mm 14, 16 x Bracket Fixing Screws, 13 x Reinforcement Fixing Screws (one for foot block).

1. Top and bottom rails should be cut to length - Distance between posts minus 15mm, allows for the thickness of two brackets and an expansion gap at each rail end. Gaps between last picket and post should not exceed 100mm. Please see matrix for bar lengths, and distance between Posts that give equal gaps.

| Number of Pickets | Nominal bar length 1828mm - Square 92mm Gap | | |
|-------------------|---|-------------------|----------------------|
| | Distance Between Posts | Cut Bar Length mm | Bar End to Hole Edge |
| 14 | 1832 | 1817 | 84.5 |
| 13 | 1707 | 1692 | |
| 12 | 1583 | 1568 | |
| 11 | 1459 | 1444 | |
| 10 | 1335 | 1320 | |
| 9 | 1210 | 1195 | |
| 8 | 1086 | 1071 | |
| 7 | 962 | 947 | |
| 6 | 838 | 823 | |
| 5 | 713 | 698 | |
| 4 | 589 | 574 | |
| 3 | 465 | 450 | |
| 2 | 341 | 326 | |
| 1 | 216 | 201 | |

Note: Cuts should be made at both ends to keep the rail routing symmetrical.

2. U Reinforcement is cut to the same length as the PVC Rail and inserted in the following orientation. Drill 2 x 10mm diameter holes in the base of the bottom rail through the reinforcement to allow for drainage.

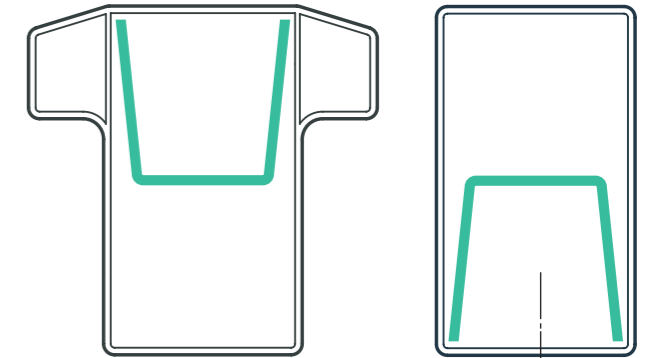

3. A foot block is secured to the underside of the bottom rail/ reinforcement at the mid-point using a 4.8mm (no10) x 19mm Self Tapping Screw. The reinforcement should be piloted with a 3.5mm drill.

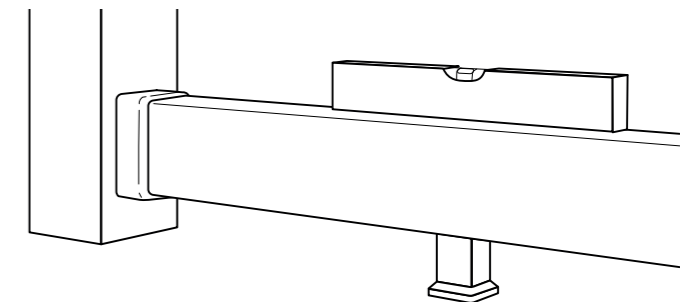

4. The height of the bottom rail bracket from the deck surface is obtained by placing the rail/foot block assembly into position with a bracket body on one end. When the bottom rail is level mark the position of the bracket onto the Post. Brackets are secured using 4 off 30mm stainless steel countersunk wood screws.

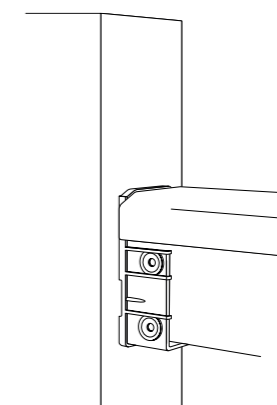

5. Assemble the top and bottom rails together with their pickets and drop the assembly into the bottom rail bracket bodies. Place a bracket body at each end of the top rail marking its position on the Post. It should be possible to lean the rail and picket assembly aside to fit the bracket bodies. Secure using 4 off 30mm stainless steel countersunk wood

screws.

- Ensure that the rails/reinforcement are centrally positioned before securing the rail assembly to the brackets via the side holes in the bracket body with 3 off 4.8mm (no10) x 19mm Self Tapping Screws. The reinforcement should be piloted with a 3.5mm drill.

Note: Only 3 of the 4 bracket holes align with the U-reinforcement.

- Brackets are finished by clipping on the bracket covers. (care should be taken not to over stress the covers).

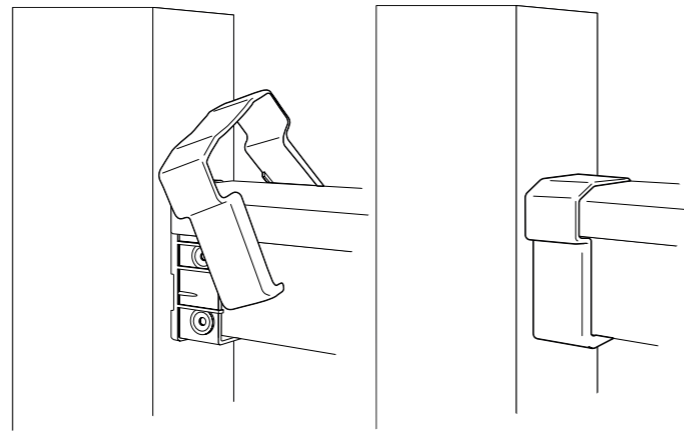

HOW TO INSTALL GATE

960mm x 950mm Gate, Hinge Pack, Latch & Lock.

- The gate is designed to align with the balustrade when using supplied Pickets in the Balustrade Kits. The top of the gate should be fitted in line with the top of the balustrade rail.
- For a 960mm wide gate the distance between posts should be 1000mm to allow for gate hardware.
- The Bottom of the gate can be identified by 2 x drainage holes.

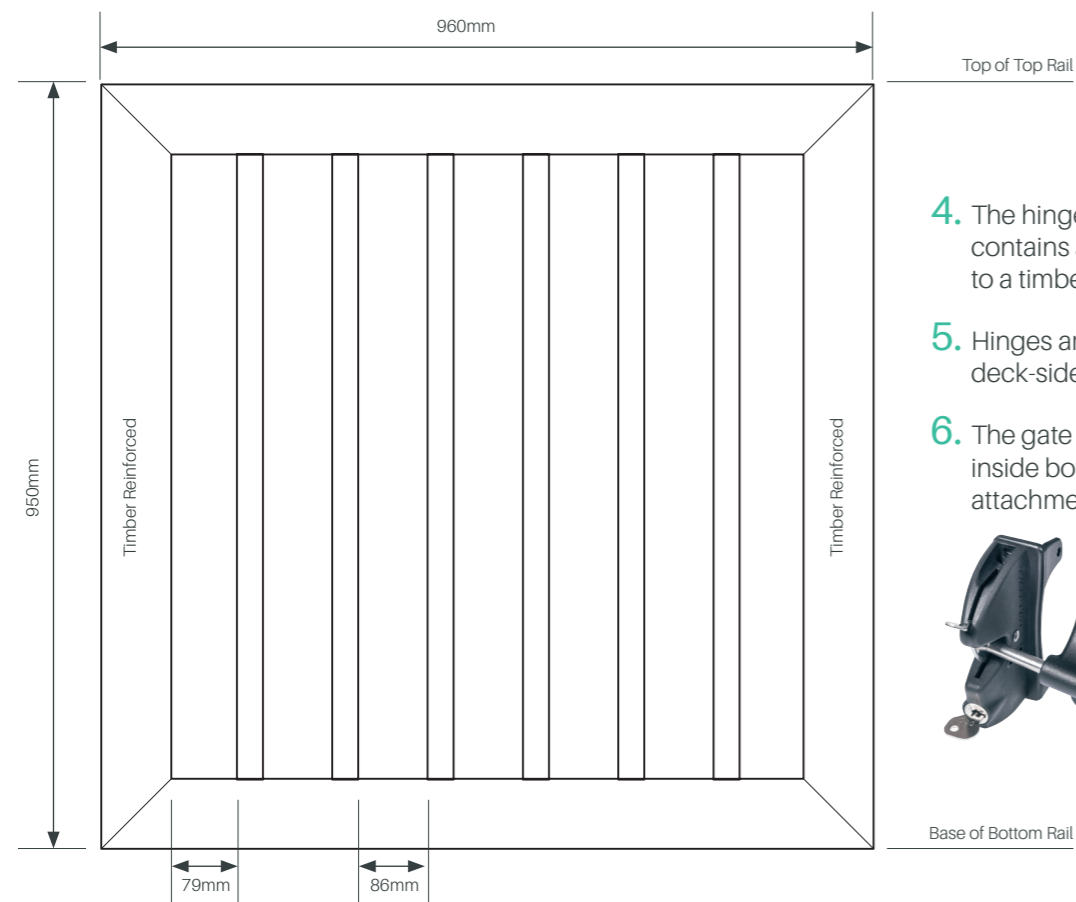

- The hinge and latch pack contains all fixings for fitting to a timber reinforced post.
- Hinges are normally placed on the deck-side of the post and gate.
- The gate has timber reinforcement inside both vertical sides for the attachment of hardware.



HOW TO INSTALL POST TO SUB FRAME

4 x Brackets, 2 x 100mm Coach Bolts per Bracket, 6 x 40mm Pan Head Screws per Bracket

- Align the inside edges of the timber sub frame to form a 90 degree corner.
- Fix bracket to sub frame using 6 x Pan Head screws.
- Place post into position and mark bracket fixing hole positions.
- Drill clearance holes in corner of PVC post at marked positions.
- Fix post with 2 x coach bolts – pilot drill holes.

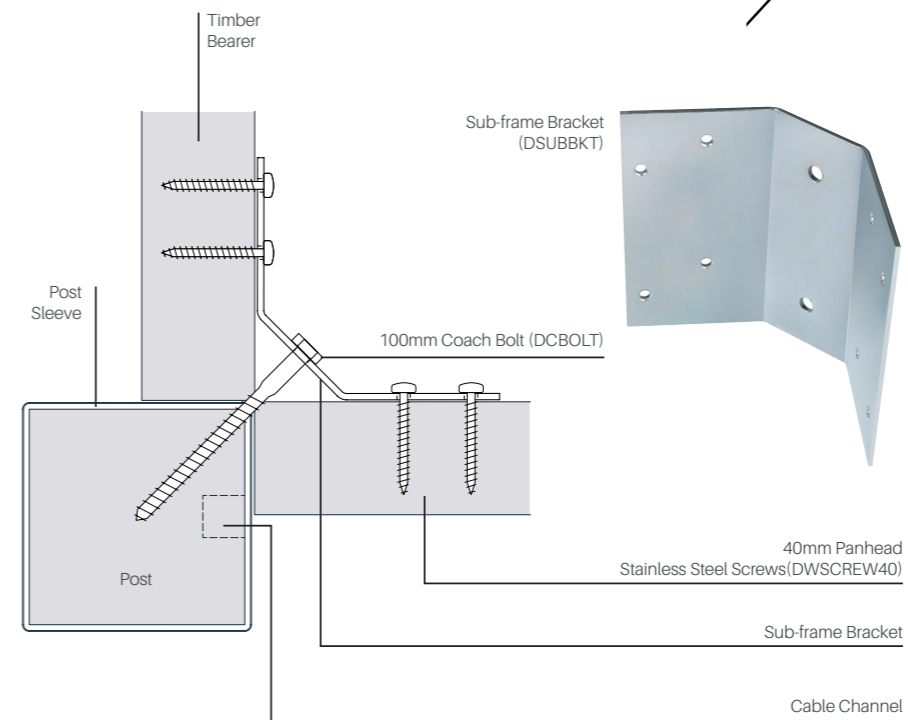
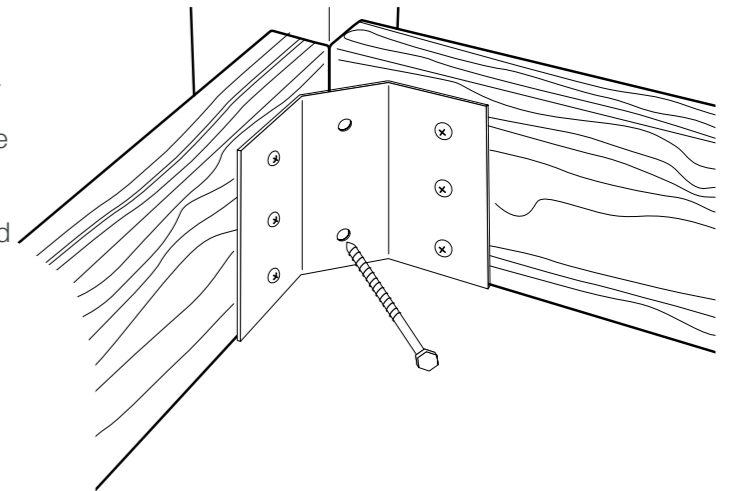



13 Abenbury Way,
Wrexham
LL13 9UZ

01978 667840
enquiries@ecodek.co.uk
ecodek.co.uk