



ecodek.co.uk

Rail Kit Installation Guide

Rail Kit Installation Guide

Within this guide, we will provide step-by-step guidance on how to install our rail kit systems.

Our rail kits are available in White and Almond:



Routing comes as Square:



Rail Kit Contents:

1828mm (6ft) Balustrade Kit

- 1 x 1828mm White/Almond Top Handrail
- 1 x 1828mm White/Almond Bottom Handrail
- 2 x Top Handrail Brackets
- 2 x Bottom Handrail Brackets
- 2 x 1828mm Steel J Channel Handrail Reinforcing
- 1 x Bottom Rail Foot Block
- 14 x 945mm x 38mm White/Almond Pickets
- 16 x Fixing Kit 30mm countersunk wood screw
- 13 x 4.8mm x 19mm Reinforcement Screws

1220mm (4ft) Balustrade Kit

- 1 x 1220mm White/Almond Top Handrail
- 1 x 1220mm White/Almond Bottom Handrail
- 2 x Top Handrail Brackets
- 2 x Bottom Handrail Brackets
- 2 x 1220mm Steel J Channel Handrail Reinforcing
- 1 x Bottom Rail Foot Block
- 9 x 945mm x 38mm White/Almond Pickets
- 16 x Fixing Kit 30mm countersunk wood screw
- 13 x 4.8 x 19mm Reinforcement Screws

Single Post Kit

- 1 x 1828mm White/Almond 102mm x 102mm Post sleeve
- 1 x Post Cap White/Almond
- 1 x Post Skirt White/Almond

Double Post Kit

- 2 x 1828mm White/Almond 102mm x 102mm Post sleeve
- 2 x Post Cap White/Almond
- 2 x Post Skirt White/Almond

Post to Subframe Fixing Kit

- 4 x Sub Frame Bracket Stainless Steel
- 2 x Coach Bolts 100mm per bracket
- 6 x 40mm Pan Head Wood Screws per bracket

Gate Kit

- 1 x Gate 960mm x 950mm
- 2 x Hinges with screws
- 1 x Latch & Lock with screws

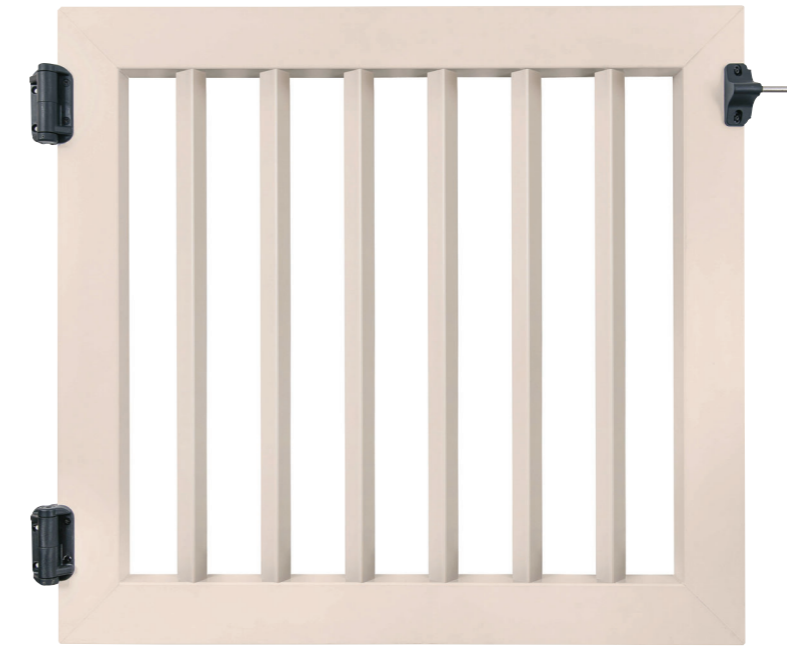
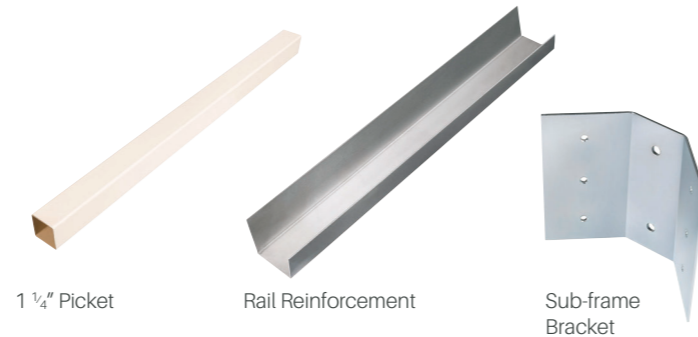

Gate



Latch



Hinges x 2



POST KIT

Single Post Kits - 3 items:
Double Post Kits - 6 items:

1 x 1828mm (6') Post, 1 x Post Cap, 1 x Post Skirt.
 2 x 1828mm (6') Post, 2 x Post Cap, 2 x Post Skirt.

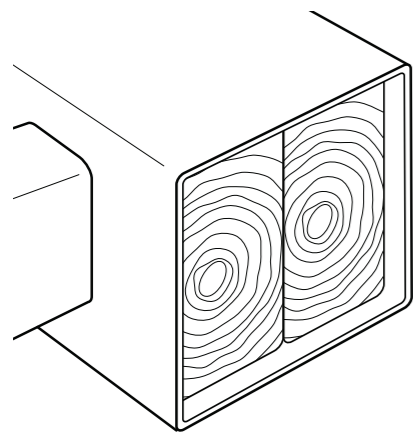
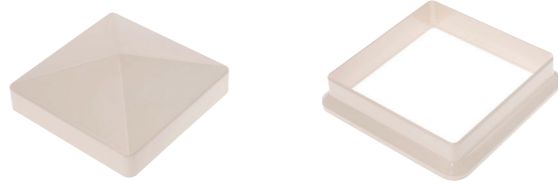

1. Post requires reinforcing with timber at nominal 95mm x 95mm – alternatively 2 off 95 x 47mm timbers screwed together at max 400mm centres can be used. Timber should be class C16 or C24. It is also recommended that timber is glued on mating faces.
2. Post and timber should be supported on a level solid base such as concrete pad.
3. Posts should be secured to deck sub-frames using one of the following methods:
 - Corners - using a Sub-Frame Bracket
 - Mid - Cross Lap Style: let into the sub-frame and supported with a backing timber on the inner side.
4. Post caps should be secured with low modulus neutral cure silicone.
5. Post skirts are used to mask the cut/expansion gap of the deck planks. Where required Skirts should be trimmed to fit and secured with low modulus neutral cure silicone.

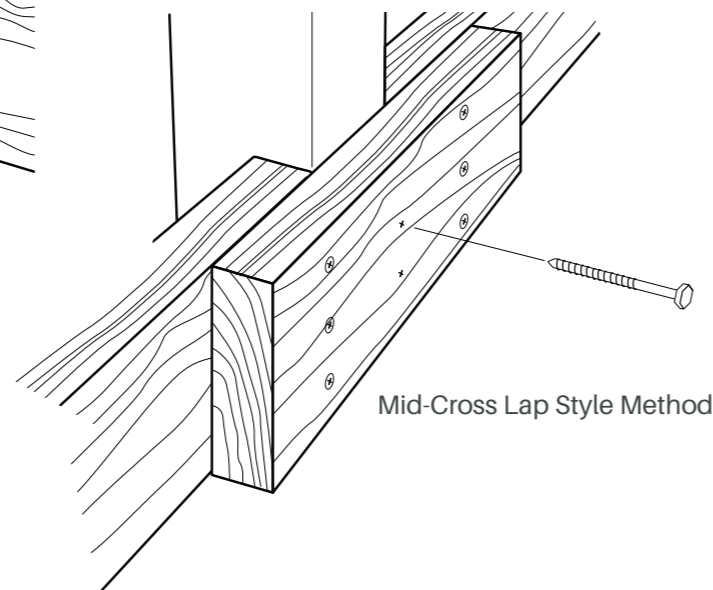
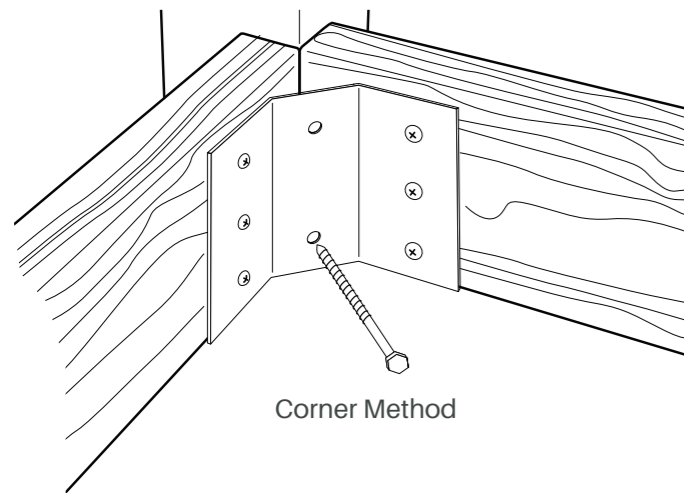

BALUSTRADE KITS 4' & 6'

Top Rail, Bottom Rail, 2 x Top Brackets, 2 x Bottom Brackets, 2 x J Channel Reinforcements, Foot Block, Pickets 945mm (9/14), Bracket Fixing Screws x 16, Reinforcement Fixing Screws x 13 (one for foot block).

1. Top and bottom rails should be cut to length - Distance between posts minus 15mm, allows for the thickness of two brackets and an expansion gap at each rail end. Gaps between last picket and post should not exceed 100mm. Please see matrix for bar lengths, and distance between Posts that give equal gaps.

Number of Pickets	Nominal bar length 1828mm - Square 92mm Gap		
	Distance Between Posts	Cut Bar Length mm	Bar End to Hole Edge
14	1832	1817	84.5
13	1707	1692	
12	1583	1568	
11	1459	1444	
10	1335	1320	
9	1210	1195	
8	1086	1071	
7	962	947	
6	838	823	
5	713	698	
4	589	574	
3	465	450	
2	341	326	
1	216	201	

Number of Pickets	Nominal bar length 1219mm - Square 93mm Gap		
	Distance Between Posts	Cut Bar Length mm	Bar End to Hole Edge
9	1220	1205	85.5
8	1095	1080	
7	970	955	
6	845	830	
5	719	704	
4	594	579	
3	469	454	
2	344	329	
1	218	203	

Note: Cuts should be made at both ends to keep the rail routing symmetrical.

2. J Reinforcement is cut to the same length as the PVC Rail and inserted in the following orientation. Drill 2 x 10mm diameter holes in the base of the bottom rail through the reinforcement to allow for drainage.

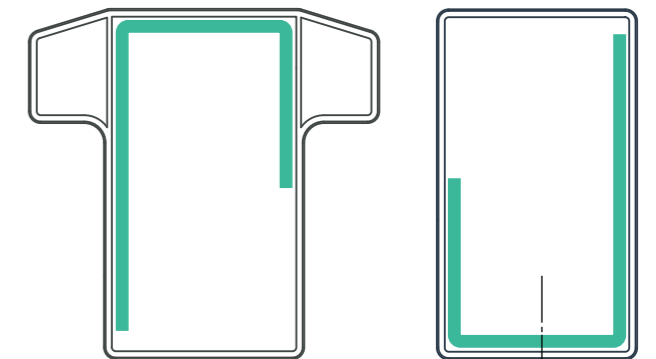

3. A foot block is secured to the underside of the bottom rail/ reinforcement at the mid-point using a 4.8mm (no10) x 19mm Self Tapping Screw. The reinforcement should be piloted with a 3.5mm drill.

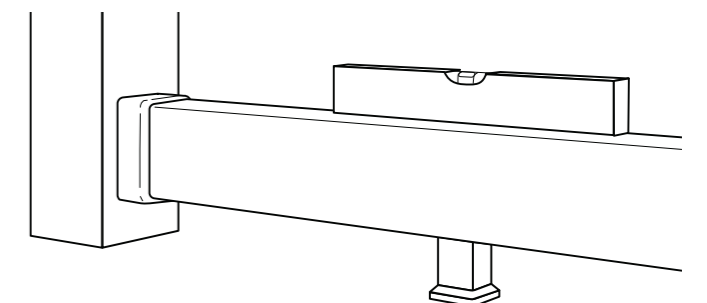

4. The height of the bottom rail bracket from the deck surface is obtained by placing the rail/foot block assembly into position with a bracket body on one end. When the bottom rail is level mark the position of the bracket onto the Post. Brackets are secured using 4 off 30mm stainless steel countersunk wood screws.

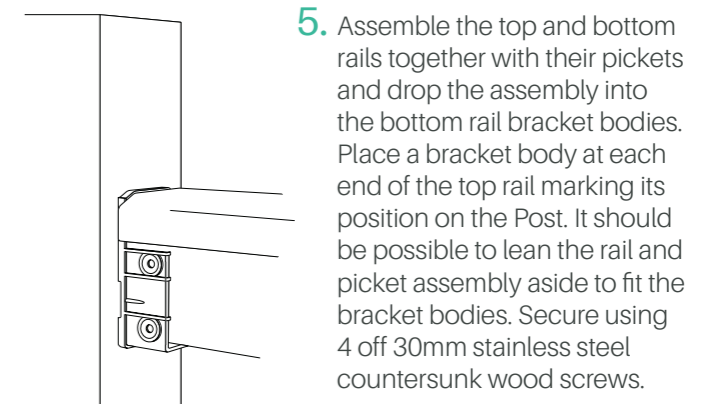

6. Ensure that the rails/reinforcement are centrally positioned before securing the rail assembly to the brackets via the side holes in the bracket body with 3 off 4.8mm (no10) x 19mm Self Tapping Screw. The reinforcement should be piloted with a 3.5mm drill.

Note: Only 3 of the 4 bracket holes align with the J-reinforcement.

7. Brackets are finished by clipping on the bracket covers. (care should be taken not to over stress the covers).

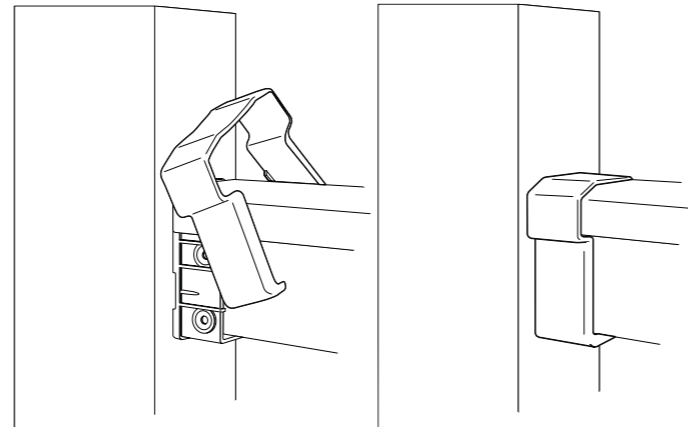

GATE KIT

960mm x 950mm Gate, Hinge Pack, Latch & Lock.

1. The gate is designed to align with the balustrade when using supplied Pickets in the Balustrade Kits. The top of the gate should be fitted in line with the top of the balustrade hand rail.
2. For a 960mm wide gate the distance between posts should be 1000mm to allow for gate hardware.
3. The Bottom of the gate can be identified by 2 x drainage holes.

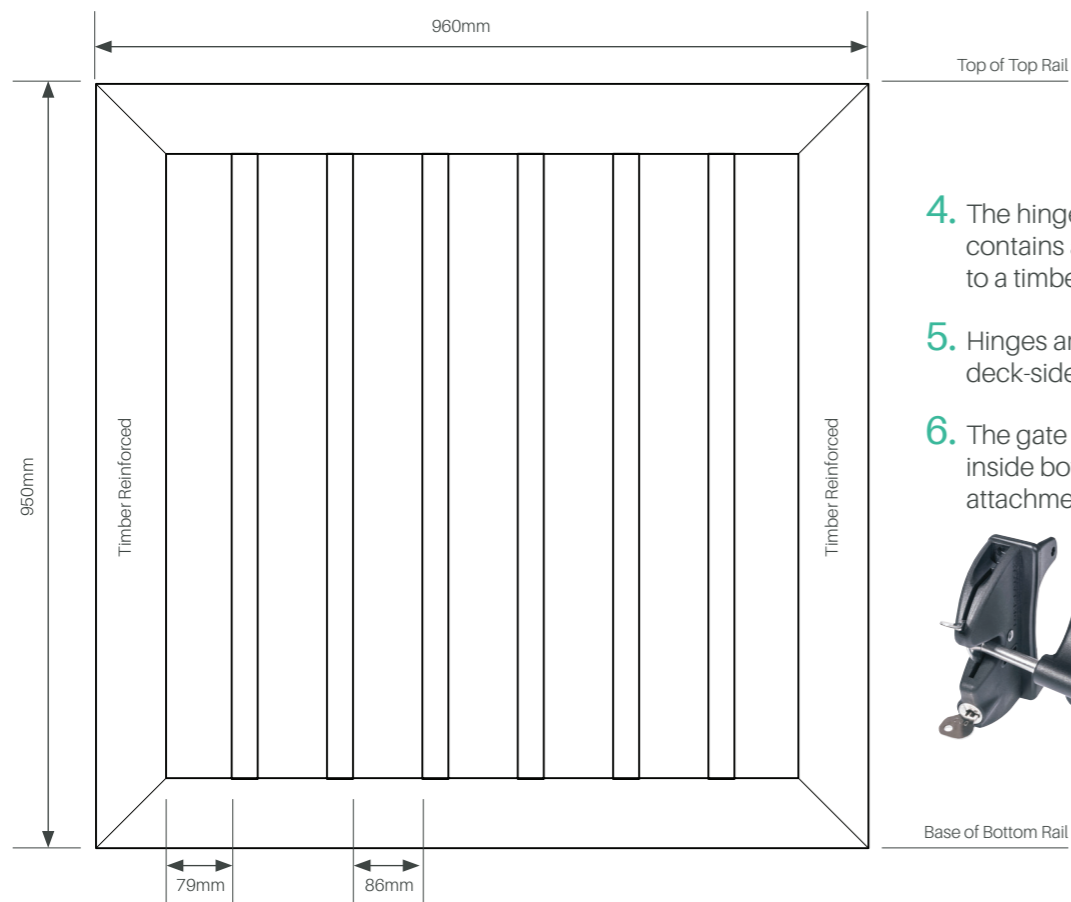

4. The hinge and latch pack contains all fixings for fitting to a timber reinforced post.
5. Hinges are normally placed on the deck-side of the post and gate.
6. The gate has timber reinforcement inside both vertical sides for the attachment of hardware.



SUB FRAME POST CONNECTING KIT

4 off (Bracket, 2 x 100mm Coach Bolt 100, 6 x 40mm Pan Head screws 40)

1. Align the inside edges of the timber sub frame to form a 90 degree corner.
2. Fix bracket to sub frame using 6 x Pan Head screws.
3. Place post into position and mark bracket fixing hole positions.
4. Drill clearance holes in corner of PVC post at marked positions.
5. Fix post with 2 x coach bolts - pilot drill holes.

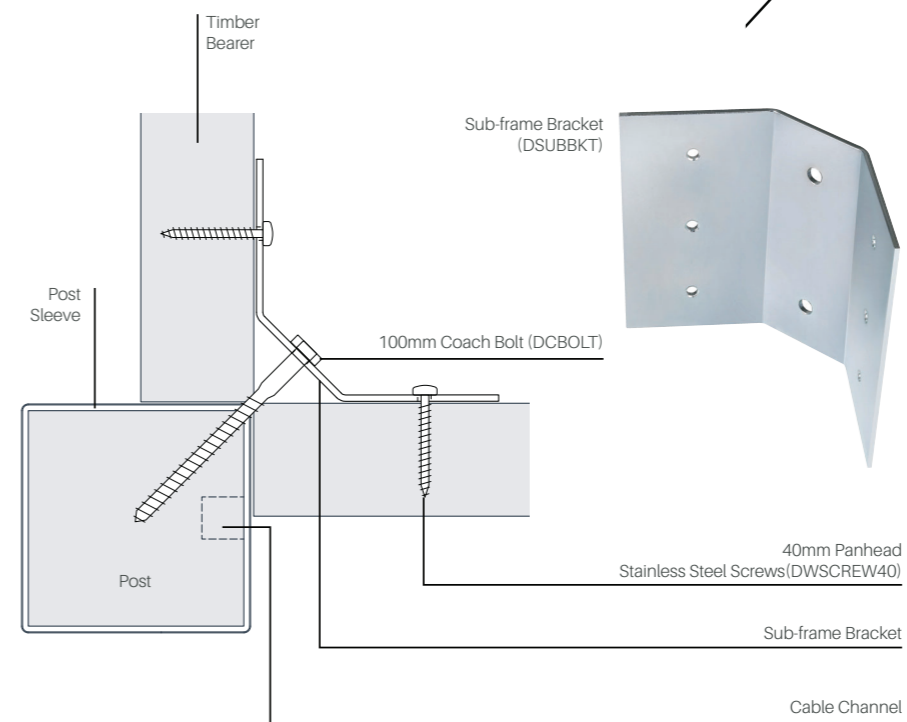
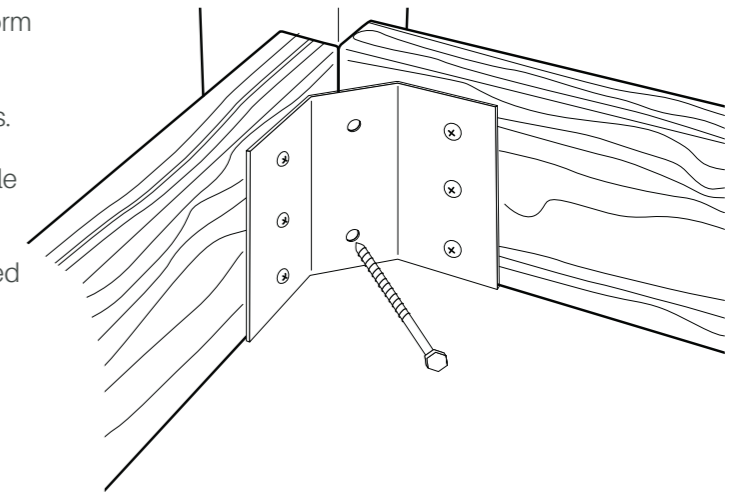



13 Abenbury Way,
Wrexham
LL13 9UZ

01978 667840
sales@ecodek.co.uk
ecodek.co.uk